

OPERATION MANUAL

airHome 400

**ROOM AIR CONDITIONER
SPLIT TYPE
DJ SERIES**

MODELS

RAK-DJ18PHAA

EN INSTRUCTION MANUAL

Page 2-15

FR MANUEL D'INSTRUCTIONS

Page 16-29

HITACHI

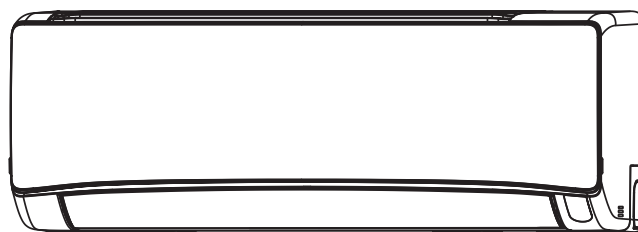

INDOOR UNIT
RAK-DJ18PHAA

(RC-AGU1EA0N)

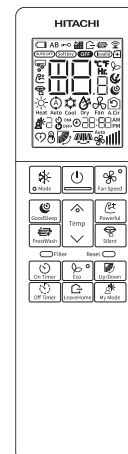

Access the full version
of the User Operation Manual by
scanning the code.
More languages available.



[https://docs.hitachiaircon.com.
RAK-DJ-PHAA-RAC-DJ-WHAA](https://docs.hitachiaircon.com/RAK-DJ-PHAA-RAC-DJ-WHAA)

Cooling & Heating

air

Important Notice

- Johnson Controls-Hitachi Air Conditioning North America LLC pursues a policy of continuing improvement in design and performance in its products. As such, Johnson Controls-Hitachi Air Conditioning North America LLC reserves the right to make changes at any time without prior notice.
- Johnson Controls-Hitachi Air Conditioning North America LLC cannot anticipate every possible circumstance that might involve a potential hazard.
- This inverter air conditioning unit is designed for standard air conditioning applications only. Do not use this unit for anything other than the purposes for which it was intended.
- The installer and system specialist shall safeguard against leakage in accordance with local codes. The following standards may be applicable, if local regulations are not available. International Organization for Standardization: (ISO 5149 or European Standard, EN 378). No part of this manual may be reproduced in any way without the expressed written consent of Johnson Controls-Hitachi Air Conditioning North America LLC.
- This air conditioning unit will be operated and serviced in the United States of America and comes with a full complement of the appropriate Safety, Danger, and Caution, Warnings.
- If you have questions, please contact your distributor or contractor.
- This manual provides common descriptions, basic and advanced information to maintain and service this air conditioning unit which you operate as well for other models.
- This air conditioning unit has been designed for a specific temperature range. For optimum performance and long life, operate this unit within the range limits.
- This manual should be considered as a permanent part of the air conditioning equipment and should remain with the air conditioning equipment.

Product Inspection upon Arrival

1. Upon receiving this product, inspect it for any damages incurred in transit. Claims for damage, either apparent or concealed, should be filed immediately with the shipping company.
2. Check the model number, electrical characteristics (power supply, voltage, and frequency rating), and any accessories to determine if they agree with the purchase order.
3. The standard utilization for this unit is explained in these instructions. Use of this equipment for purposes other than what it designed for is not recommended.
4. Please contact your local agent or contractor as any issues involving installation, performance, or maintenance arise. Liability does not cover defects originating from unauthorized modifications performed by a customer without the written consent of Johnson Controls-Hitachi Air Conditioning North America LLC. Performing any mechanical alterations on this product without the consent of the manufacturer will render your warranty null and void.

California Proposition 65



Proposition 65: This product contains chemicals known to the state of California to cause cancer, birth defects, and other reproductive harm. For more information, go to www.P65Warnings.ca.gov



SAFETY PRECAUTION

- Please read the "Safety Precaution" carefully before operating the unit to ensure correct usage of the unit.
- Pay special attention to signs of "▲ Warning" and "▲ Caution". The "Warning" section contains matters which, if not observed strictly, may cause death or serious injury. The "Caution" section contains matters which may result in serious consequences if not observed properly. Please observe all instructions strictly to ensure safety.
- The sign indicate the following meanings.

	Make sure to connect earth line.		The sign in the figure indicates prohibition.
	Indicates the instructions that must be followed.		

	WARNING	This symbol shows that this equipment uses a flammable refrigerant. If the refrigerant is leaked, together with an external ignition source, there is a possibility of ignition.
	CAUTION	This symbol shows that the Operation Instructions should be read carefully.
	CAUTION	This symbol shows that a service personnel should be handling this equipment with reference to the Installation Manual.
	CAUTION	This symbol shows that there is information included in the Operation Manual and/or Installation Manual

- Please keep this manual after reading.

PRECAUTIONS DURING INSTALLATION

	WARNING	<ul style="list-style-type: none"> • Do not reconstruct the unit. Water leakage, fault, short circuit or fire may occur if you reconstruct the unit by yourself. • Please ask your sales agent or qualified technician for the installation of your unit. Water leakage, short circuit or fire may occur if you install the unit by yourself.
		<ul style="list-style-type: none"> • Please use earth line. Do not place the earth line near water or gas pipes, lightning-conductor, or the earth line of telephone. Improper installation of earth line may cause electric shock.
		<ul style="list-style-type: none"> • Be sure to use the specified piping set for R32. Otherwise, this may result in broken copper pipes or faults. • Do not use refrigerant other than the one indicated on the outdoor unit (R32) when installing, moving or repairing. Using other refrigerants may cause trouble or damage to the unit, and personal injury.
		<ul style="list-style-type: none"> • A circuit breaker should be installed depending on the mounting site of the unit. Without a circuit breaker, the danger of electric shock exists. • Do not install near location where there is flammable gas. The outdoor unit may catch fire if flammable gas leaks around it. • Please ensure smooth flow of water when installing the drain hose. • Do not install the indoor unit in a machine shop, kitchen and laundry rooms when vapor from oil or its mist flows to the indoor unit. The oil will deposit on the heat exchanger, thereby reducing the indoor unit performance and may deform and in the worst case, break the plastic parts of the indoor unit.

PRECAUTIONS DURING SHIFTING OR MAINTENANCE

	WARNING	<ul style="list-style-type: none"> • Should abnormal situation arises (like burning smell), please stop operating the unit and turn off the circuit breaker. Contact your agent. Fault, short circuit or fire may occur if you continue to operate the unit under abnormal situation.
		<ul style="list-style-type: none"> • Please contact your agent for maintenance. Improper self maintenance may cause electric shock and fire.
		<ul style="list-style-type: none"> • Please contact your agent if you need to remove and reinstall the unit. Electric shock or fire may occur if you remove and reinstall the unit yourself improperly.
		<ul style="list-style-type: none"> • If the supply cord is damaged, it must be replaced by the special cord obtainable at authorized service/parts centers.
		<ul style="list-style-type: none"> • If the air conditioner is not cool, one possible cause could be due to refrigerant leakage, so consult your dealer. The refrigerant gas used in the air conditioner is harmless. But if refrigerant gas leaks into the room, harmful products are generated when in contact with fire from appliances such as a stove heater. When there is refrigerant gas accumulation in the room, immediately stop the air conditioner. Open the windows for ventilation and contact your agent.

PRECAUTIONS DURING OPERATION

	WARNING	<ul style="list-style-type: none"> • Avoid an extended period of direct air flow for your health.
		<ul style="list-style-type: none"> • Do not insert a finger, a rod or other objects into the air outlet or inlet. As the fan is rotating at a high speed, it will cause injury. Before cleaning, be sure to stop the operation and turn the breaker OFF.
		<ul style="list-style-type: none"> • Do not use any conductor as fuse wire, this could cause fatal accident.
		<ul style="list-style-type: none"> • During thunder storm, disconnect and turn off the circuit breaker.
		<ul style="list-style-type: none"> • Spray cans and other combustibles should not be located within a meter of the air outlets of both indoor and outdoor units. As a spray can's internal pressure can be increased by hot air, a rupture may result.

PRECAUTIONS DURING OPERATION

- The product shall be operated under the manufacturer specification and not for any other intended use.

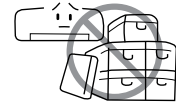

- Do not attempt to operate the unit with wet hands, this could cause fatal accident.

- When operating the unit with burning equipments, regularly ventilate the room to avoid oxygen insufficiency.

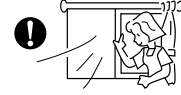

- Do not direct the cool air coming out from the air-conditioner panel to face household heating apparatus as this may affect the working of apparatus such as the electric kettle, oven etc.

- Please ensure that outdoor mounting frame is always stable, firm and without defect. If not, the outdoor unit may collapse and cause danger.



- Do not splash or direct water to the body of the unit when cleaning it as this may cause short circuit.

- Do not use any aerosol or hair sprays near the indoor unit. This chemical can adhere on heat exchanger fin and blocked the evaporation water flow to drain pan. The water will drop on tangential fan and cause water splashing out from indoor unit.

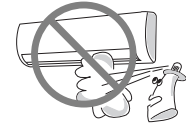

- Please switch off the unit and turn off the circuit breaker during cleaning, the high-speed fan inside the unit may cause danger.



- Turn off the circuit breaker if the unit is not to be operated for a long period.



- Do not climb on the outdoor unit or put objects on it.

- Do not put water container (like vase) on the indoor unit to avoid water dripping into the unit. Dripping water will damage the insulator inside the unit and causes short-circuit.

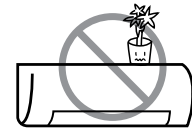

- Do not place plants directly under the air flow as it is bad for the plants.

- When operating the unit with the door and windows opened, (the room humidity is always above 80%) and with the air deflector facing down or moving automatically for a long period of time, water will condense on the air deflector and drips down occasionally. This will wet your furniture. Therefore, do not operate under such condition for a long time.

- If the amount of heat in the room is above the cooling or heating capability of the unit (for example: more people entering the room, using heating equipments and etc.), the preset room temperature cannot be achieved.

- This appliance can be used by children aged from 8 years and above and persons with reduced physical, sensory or mental capabilities or lack of experience and knowledge if they have been given supervision or instruction concerning use of the appliance in a safe way and understand the hazards involved. Children shall not play with the appliance. Cleaning and user maintenance shall not be made by children without supervision.



C
A
U
T
I
O
N

Operation Range

Operation mode	Cooling/Dehumidifying	Heating
Outdoor temperature	-0.4°F (-18°C) to 114.8°F (46°C)	-5°F (-20.55°C) to 75.2°F (24°C)

Names and Functions of Each Part

Indoor Unit

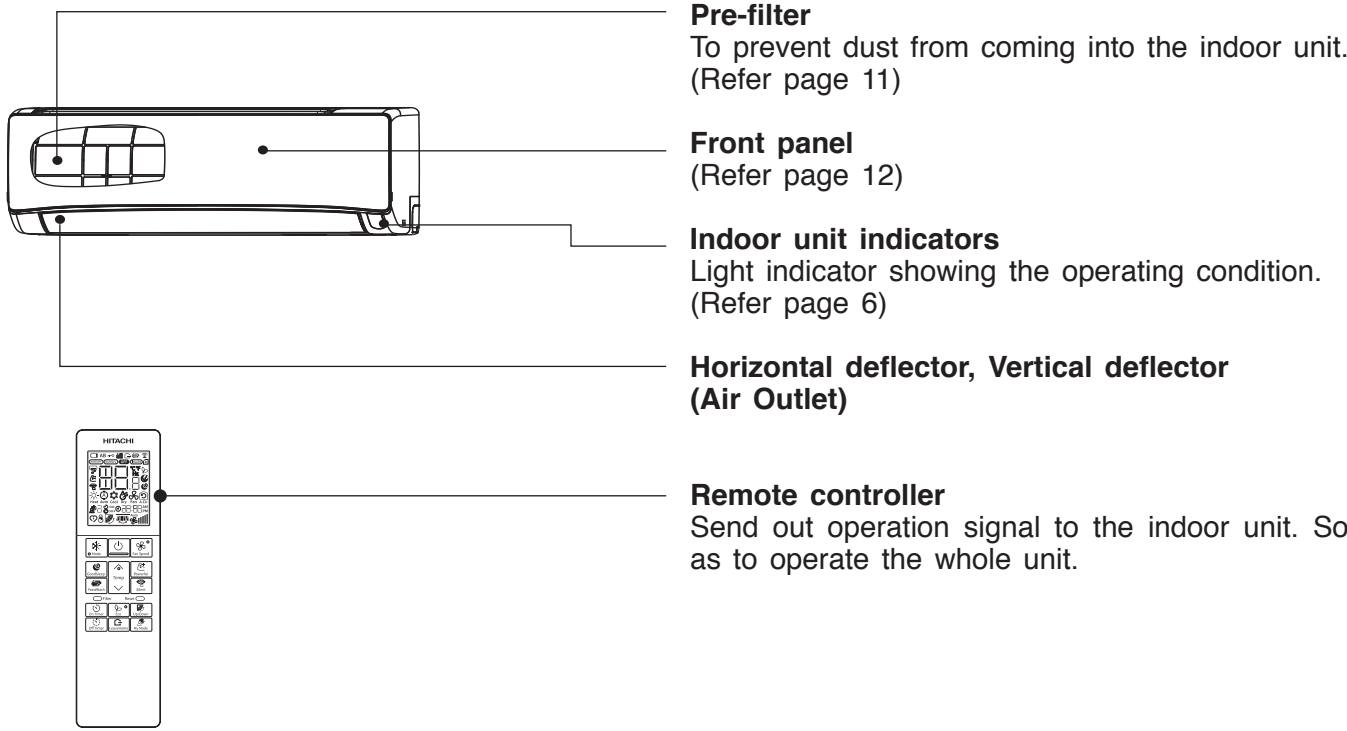

Model Name and Dimensions

MODEL	WIDTH in(mm)	HEIGHT in(mm)	DEPTH in(mm)
RAK-DJ18PHAA	37-13/32" (950)	11-18/32" (294)	9-2/32" (230)

NAMES AND FUNCTIONS OF EACH PART

INDOOR UNIT INDICATIONS

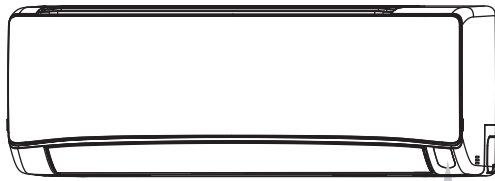

Operation Lamp (Yellow)

This lamp lights during operation.

Timer Lamp (Orange)

This lamp lights when the timer is working.

Wi-Fi Lamp (Blue)

Optional

Clean Function Lamp (Green)

This lamp uses for FrostWash, Mold Guard, Filter Sign.

Temporary Switch

Use this switch to start and stop when the remote controller does not work.

- By pressing the temporary switch, the operation is done in automatic mode.
- When the operation is done using the temporary switch after the power source is turned off and turn on again, the operation is done in automatic mode.

⚠ CAUTION

Turn off the circuit breaker if the unit is not be operated for a long period.

☆ If the power stays on and the unit is not operated, power is slightly consumed in the control circuit. The power is saved by turning off the power switch (or the circuit breaker when the power is supplied from the outdoor unit).

INFORMATION

Capabilities

CAUTION

Do not use a stove or any other high temperature devices in proximity to the indoor unit.



PROHIBITION

Cooling and Dehumidifying Capabilities

- If the heat present in a room exceeds the unit's cooling capacity (for example, if there are many people in the room or other heating appliances are used), the preset room temperature may not be reached.

Refrigerant Information

- For the refrigerant charge information, please refer to the outdoor unit installation manual or specification label.

Names and Functions of Remote Controller

■ This remote controller controls the operation function and timer setting of the room air conditioner. The operating range of the remote controller is about 7 meters. If indoor lighting is controlled electronically, the range of control may be shorter.

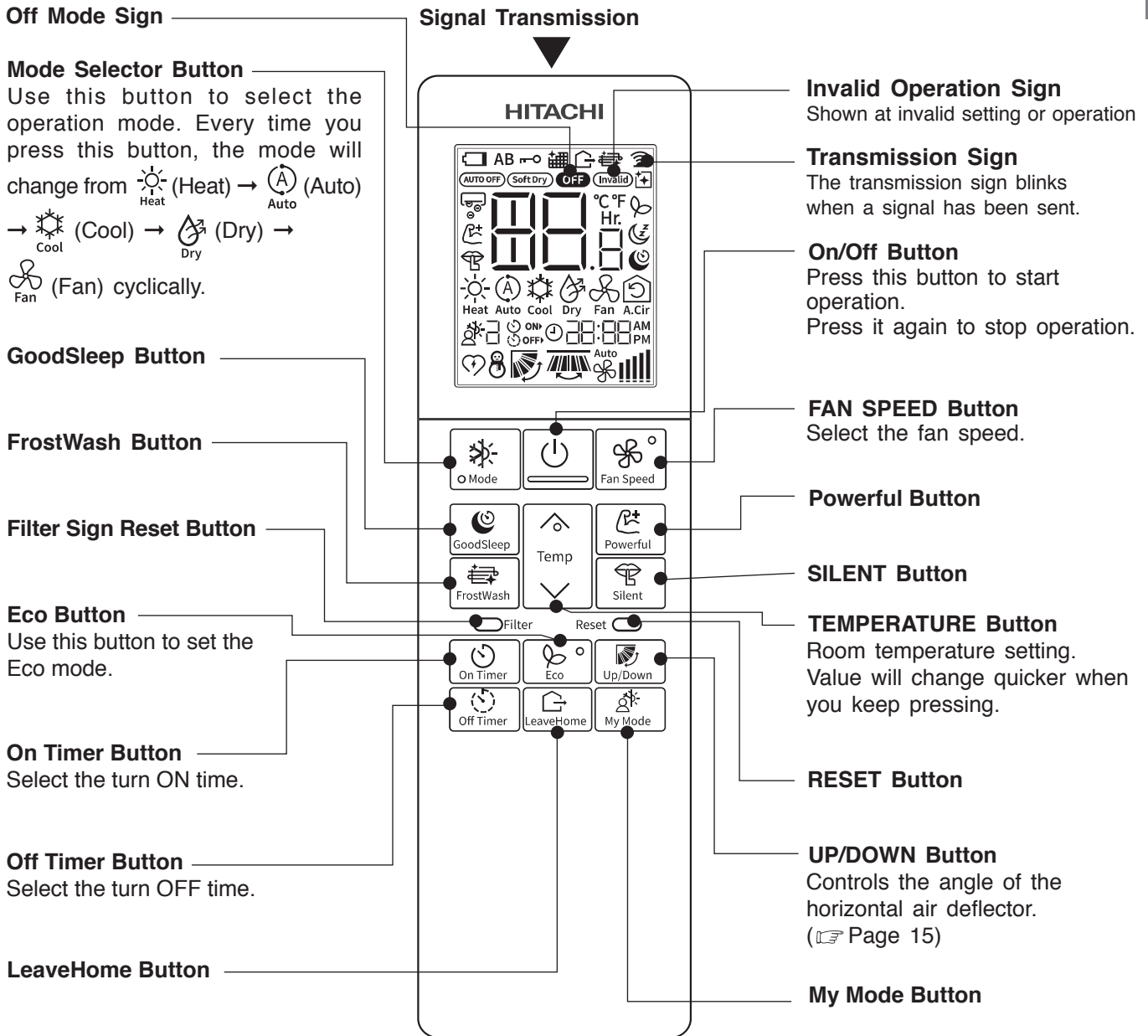

Backlight function

- Backlight is to see the LCD readings in the dark.
- On pressing any key, the LCD panel lights up for a period of approx. 10 seconds. After approx. 10 seconds the light automatically switches off.
- The function is independent of all other functions of the air conditioner.
- The backlight color is white.

Precautions for Use

- Do not put the remote controller under direct sunlight and high temperature.
- Do not drop it on the floor, and protect it from water.
- If you press the Mode button during operation, the air conditioner may stop for about 3 minutes for protection before you can start it again.

THE IDEAL WAYS OF OPERATION

Suitable Room Temperature



⚠ Warning

Freezing temperature is bad for health and a waste of electric power.

Install curtain or blinds

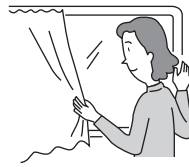

It is possible to reduce heat entering the room through windows.

Ventilation



⚠ Caution

Do not close the room for a long period of time. Occasionally open the door and windows to allow the entrance of fresh air.

Do Not Forget To Clean The Pre-Filter

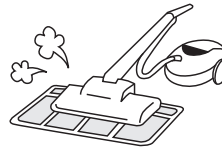

Dusty air filter will reduce the air volume and the cooling efficiency. To prevent from wasting electric energy, please clean the filter every 2 weeks.

Effective Usage Of Timer

At night, please use the "OFF or ON timer or SLEEP timer operation mode", together with your wake up time in the morning. This will enable you to enjoy a comfortable room temperature. Please use the timer effectively.



Please Adjust Suitable Temperature For Baby And Children



Please pay attention to the room temperature and air flow direction when operating the unit for baby, children and old folks who have difficulty in movement.

FOR USER'S INFORMATION

The Air Conditioner And The Heat Source In The Room

⚠ Caution

If the amount of heat in the room is above the cooling capability of the air conditioner (for example: more people entering the room, using heating equipments and etc.), the preset room temperature cannot be achieved.



Not Operating For A Long Time

When the indoor unit is not to be used for a long period of time, please switch off the power from the mains. If the power from mains remains "ON", the indoor unit still consumes about 3W in the operation control circuit even if it is in "OFF" mode.

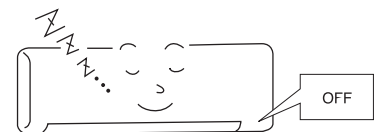

When Lightning Occurs

⚠ Warning

To protect the whole unit during lightning, please stop operating the unit and remove the plug from the socket.

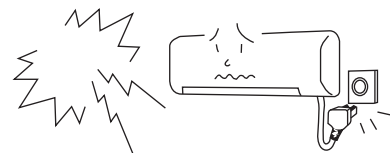

Interference From Electrical Products

⚠ Caution

To avoid noise interference, please place the indoor unit and its remote controller at least 1m away from electrical products.

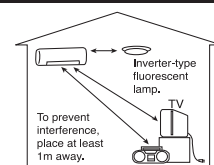

AIRFLOW LOUVERS ADJUSTMENTS

Adjustment of the conditioned air to the left and right.

Hold the second vertical louver of each set of vertical louver from right as shown in the figure and adjust the conditioned air to the left or right.

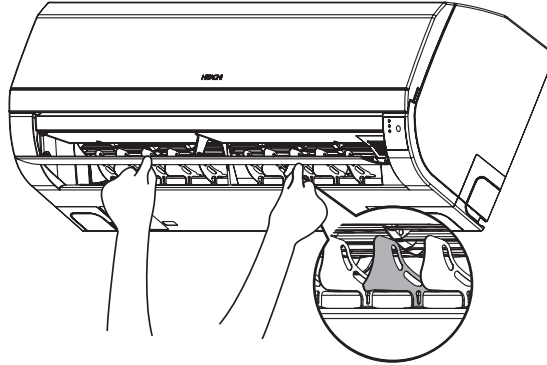

⚠ WARNING

Do not insert a finger, a rod or other objects into the air outlet or inlet as the fan is rotating at a high speed, it will cause injury. Before any cleaning or adjusting the louvers, be sure to switch OFF the operation.

ATTACHING THE AIR PURIFYING FILTERS

1 Open the front panel

- Pull up the front panel by holding it at both sides with both hands.

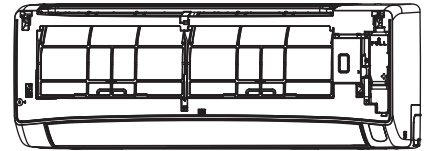

2 Remove the Pre-filter

- Push upward to release the claws and pull out the Pre-filter.

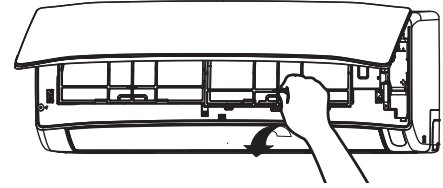

3 Attaching the air purifying filters (Accessories) to the filter frame.

- Attach the air purifying filters to the C-case to the designated position.
- The cooling capacity is slightly weakened and the cooling speed becomes slower when the air purifying filters are used.
- The air purifying filters are not washable. It is recommended to use vacuum to clean. It can be used for 1 year. When you want to renew it, please ask your sales agent.

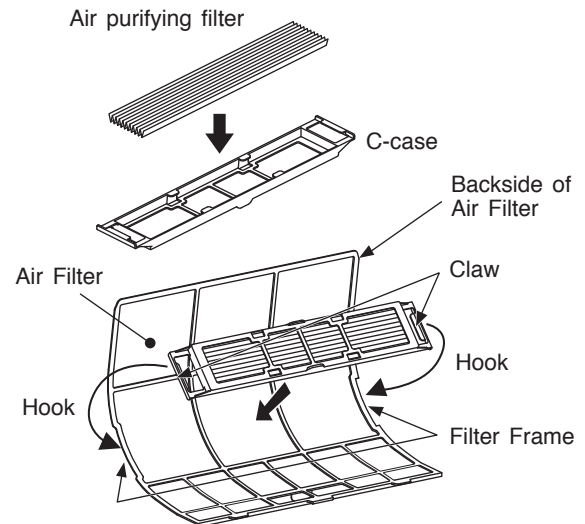

CAUTION

Do not bend the air purifying filter as it may cause damage to the structure.

Please do not smell direct from source of filter.

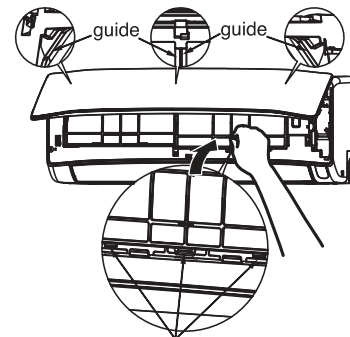

insert the hook to the hole

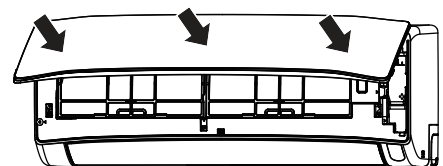

4 Attach the Pre-filters

- Attach the Pre-filters by ensuring that the surface written "FRONT" is facing front.
- After attaching the Pre-filters, push the front panel at three arrow portions as shown in figure and close it.

NOTE

- In case of removing the air purifying filters, please follow the above procedures.
- The cooling capacity is slightly weakened and the cooling speed becomes slower when the air purifying filters are used. So, set the fan speed to "HIGH" when using it in this condition.
- Air purifying filters are not washable. It is recommended to use vacuum to clean it. It can be use for 1 year time. Type number for this air purifying filter is <SPX-CFH22AC25>. Please use this number for ordering when you want to renew it.
- Do not use detergent on the air purifying filter as some detergent may deteriorate the air purifying filter electrostatic performance.

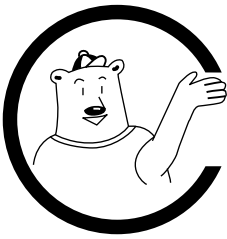

MAINTENANCE

⚠ CAUTION

Before cleaning, stop operation and switch off the power supply.

1. PRE-FILTER

Clean the Pre-filter, as it removes dust inside the room. In case the Pre-filter is full of dust, the air flow will decrease and the cooling capacity will be reduced. Further, noise may occur. Be sure to clean the Pre-filter following the procedure below.

PROCEDURE

- 1 Open the front panel and remove the Pre-filter
 - Gently lift and remove the air purifying filters from the air purifying filter frame.

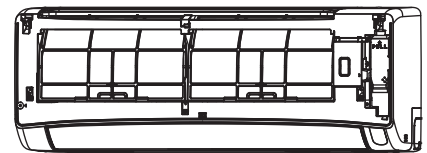

- 2 Vacuum dust from the Pre-filter and air purifying filter using vacuum cleaner. If there is too much dust, rinse under running tap water and gently brush it with soft bristle brush. Allow filters to dry in shade.

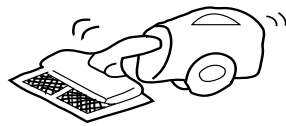
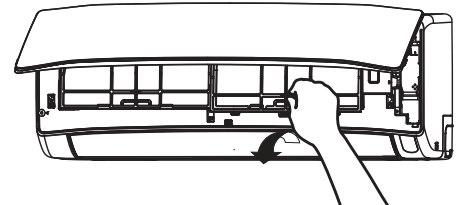

- 3
 - Re-insert the air purifying filter to the filter frame. Set the Pre-filter with "FRONT" mark facing front, and slot them into the original state.
 - After attaching the Pre-filters, push the front panel at three arrow portions as shown in figure and close it.

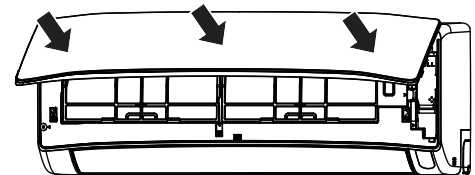
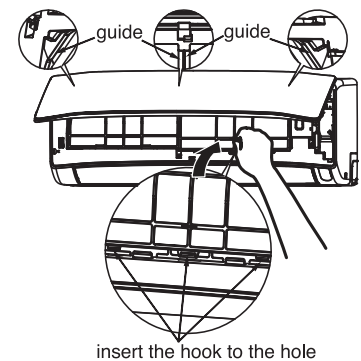

⚠ CAUTION

- Do not wash with hot water at more than 104°F(40°C).. The Pre-filters may shrink.
- When washing it, shake off moisture completely and dry it in the shade; do not expose it directly to the sun. The Pre-filters may shrink.
- Do not use detergent on the Pre-filter as some detergent may deteriorate the Pre-filter electrostatic performance.

2. CLEANING OF FRONT PANEL

- Remove the front panel and wash with clean water. Wash it with a soft sponge. After using neutral detergent, wash thoroughly with clean water.
- When front panel is not removed, wipe it with a soft dry cloth. Wipe the remote controller thoroughly with a soft dry cloth.
- Wipe the water thoroughly. If water remains at indicators or signal receiver of indoor unit, it causes trouble.

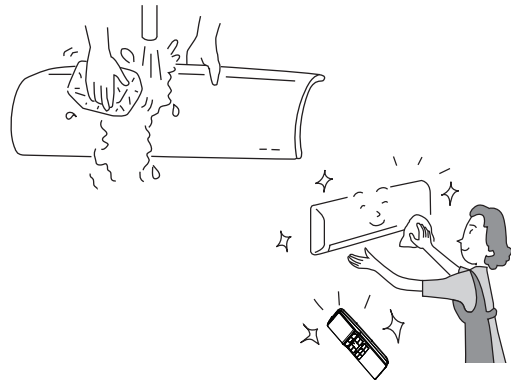

Method of removing the front panel.

Be sure to hold the front panel with both hands to detach and attach it.

Removing the Front Panel

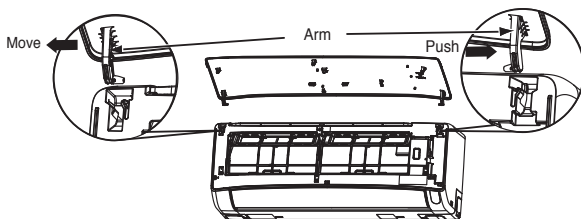

- When the front panel is fully opened with both hands, push the right arm to the outside to release it, and while closing the front panel slightly, pull it out forward.

Attaching the Front Panel

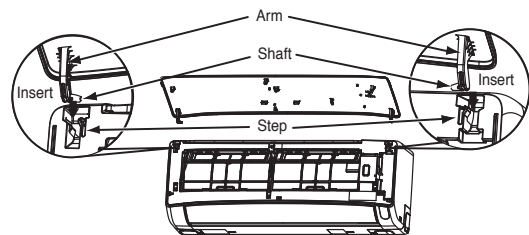

- Move the projections of the left and right arms into the Flanges in the unit and securely insert them into the holes.

CAUTION

- Never use hot water (above 40°C), benzene, gasoline, acid, thinner or a brush, because they will damage the plastic surface and the coating.



WIRING ARRANGEMENT

CAUTION

- Please use earth line. Do not place the earth line near water or gas pipes, lightning-conductor, or the earth line of telephone. Improper installation of earth line may cause electric shock
- A circuit breaker should be installed depending on the mounting site of the unit. Without a circuit breaker, the danger of electric shock exists.



IMPORTANT

The wires in this mains lead are coloured in accordance with the following code:

Green-and-yellow	: Earth
Blue	: Neutral
Brown	: Live

As the colours of the wires in the mains lead of this appliance may not correspond with the coloured markings identifying the terminals in your plug, proceed as follows:

The wire which is coloured green-and-yellow must be connected to the terminal in the plug which is marked with the letter E or by the earth symbol (⊕) or coloured green or green-and-yellow.

The wire which is coloured blue must be connected to the terminal which is marked with the letter N or coloured black.

The wire which is coloured brown must be connected to the terminal which is marked with the letter L or coloured red.

NOTE



If the supply cord is damaged, it must be replaced by the special cord obtainable at authorized service/parts centers.

CAUTION

Cleaning and maintenance must be carried out only by qualified service personnel. Before cleaning, stop operation and switch off the power supply.

Regular Inspection

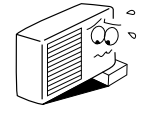
PLEASE CHECK THE FOLLOWING POINTS BY QUALIFIED SERVICE PERSONNEL EITHER EVERY HALF YEARLY OR YEARLY. CONTACT YOUR SALES AGENT OR SERVICE SHOP.

1		Is the earth line disconnected or broken?
2		Is the mounting frame seriously affected by rust and is the outdoor unit tilted or unstable?
3		Is the plug of power line firmly plugged into the socket? (Please ensure no loose contact between them).

AFTER SALE SERVICE AND WARRANTY

WHEN ASKING FOR SERVICE, CHECK THE FOLLOWING POINTS

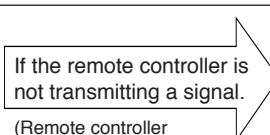
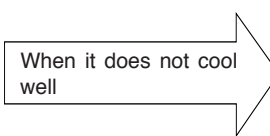
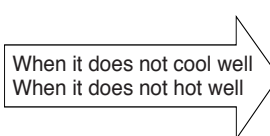
CONDITION	CHECK THE FOLLOWING POINTS
 <p>If the remote controller is not transmitting a signal. (Remote controller display is dim or blank.)</p>	<ul style="list-style-type: none"> Do the batteries need replacement? Is the polarity of the inserted batteries correct?
 <p>When it does not cool well</p>	<ul style="list-style-type: none"> Is the fuse all right? Is the voltage extremely high or low? Is the circuit breaker "ON"? Is the setting of operation mode different from other indoor units?
 <p>When it does not cool well When it does not heat well</p>	<ul style="list-style-type: none"> Is the pre-filter blocked with dust? Does sunlight fall directly on the outdoor unit? Is the air flow of the outdoor unit obstructed? Are the doors or windows opened, or is there any source of heat in the room? Is the set temperature suitable? Are the air inlets or air outlets of indoor and outdoor units blocked? Is the fan speed "LOW" or "SILENT"?

FrostWash Operation

FrostWash Operation does not start	<p>It does not wash when outside temperature is less than about 1 degrees Celsius or more than 43 degrees Celsius.</p> <p>It does not wash when the humidity in the room is about 30% or less or about 70% or more.</p> <p>When "FrostWash" is done by operating a remote controller, it does not wash when the room temperature is less than about 10 degrees Celsius or more than about 32 degrees Celsius.</p>
Noise occurred during FrostWash operation	<p>When 60 minutes after the end of "FrostWash", "FrostWash" is not operated for product protection.</p> <p>It is the sound that the internal machine is inflated and contracted by the temperature change and the fin of the heat exchanger is frozen and thawed</p>
 (Clean Function Lamp) blinks	<p>Repeat for 1 second on and 1 second off for 10 seconds</p> <p>Because "FrostWash" can not work when operating the "FrostWash" with remote controller.</p> <ul style="list-style-type: none"> The air conditioner is operating Outside air temperature, room temperature and room humidity are not suitable for "FrostWash" It has not been over 60 minutes since the end of "FrostWash"
	<p>Repeat for 4 seconds on and 1 second off for 15 seconds</p> <p>Because FrostWash has not been done for a long time.</p> <p>→ Operate the remote controller to operate "FrostWash".</p>

Mold Guard Operation

Mold Guard operation does not start	<p>If the air conditioner operation is stopped after heating operation, Mold Guard will not operate.</p> <p>If the air conditioner has operated in cooling and drying mode, including auto mode, for less than 10 minutes, the Mold Guard operation will not start even if the air conditioner is in off mode.</p> <p>If operation of the air conditioner is stop by OFF Timer or GoodSleep Timer, the Mold Guard will not operate.</p> <p>If ON Timer is set and on time is within about 2 hours, the Mold-Guard will not operate.</p>
During Mold Guard	<p> (Clean Function Lamp) on the indoor unit lights up during Mold Guard operation. If Mold Guard operation stop at middle point, FrostWash and Filter sign indicator will turn off.</p>

Notes	<p>The horizontal deflector remain open. Room temperature or humidity may rise. Depending on situation, Mold Guard will operate with Fan Mode.</p> <p>When there would be the window near indoor unit, the water might condense on the window during Mold Guard. If necessary, to cancel Mold Guard.</p> <p>When after FrostWash operation, the water inside the indoor unit evaporates and depending on the room conditions, may emitted as steam. But this is not a malfunction. If necessary, to cancel Mold-Guard.</p>
-------	--

The OPERATION lamp is flashing	Shows preheating or defrosting operation is underway. As the protective circuit or preheat sensor operates when unit operation is stopped during preheating and then restarted, or when operation mode is switched from cooling to heating, the lamp continues to blink.
Does not reach the temperature setting	Actual room temperature may deviate slightly from the remote controller's temperature setting depending on the number of people in the room, indoor or outdoor conditions.

■ The following phenomena do not indicate unit failure.

During heating, the operation indicator blinks and air blow stops	<p><Operation start> The unit is preparing to blow warm air. Please wait.</p> <p><In operation> The outdoor unit is defrosting. Please wait.</p>
Hissing or fizzy sounds	Refrigerant flow noise in the pipe or valve sound generated when flow rate is adjusted.
	Refrigerant flow noise occur during changes of maximum fan speed to lowest speed.
Squeaking noise	Noise generated when the unit expands or contracts due to temperature changes.
Rustling noise	Noise generated with the indoor unit fan's rpm changing such as operation start times.
Clicking noise	Noise of the motorized valve when the unit is switched on.
Perking noise	Noise of the ventilation fan sucking in air present in the drain hose and blowing out dehumidifying water that had accumulated in the condensed water collector. For details, consult your sales agent.
Changing operation noise	Operation noise changes due to power variations according to room temperature changes.
Mist emission	Mist is generated as the air within the room is suddenly cooled by conditioned air.
Steam emitted from the outdoor unit	Water generated during defrosting operation evaporates and steam is emitted.
Odors	Caused as the smells and particles of smoke, food, cosmetics, etc. present in room air become attached the unit and blown off into the room again.
The outdoor unit continues to operate even if operation is stopped.	Defrosting is underway (as the heating operation is stopped, the microcomputer checks frost accumulated in the outdoor unit and instructs the unit to perform automatic defrosting if necessary).

If the unit still fails to operate normally after performing the above inspections, turn the circuit breaker off and contact your sales agent immediately.

Contact your sales agent immediately if the following phenomena should occur

- The circuit breaker switches off or the fuse blows frequently.
- The switch operation is not stable.
- Foreign matter or water accidentally enters the unit interior.
- The power cord gets excessively hot or its insulation is torn or stripped.
- TIMER lamp on the indoor unit display blinks. (As the nature of the failure can be identified by the blinking cycle, check the blinking cycle before turning off the circuit breaker.)



Notes

- In quiet operation or stopping the operation, the following phenomena may occasionally occur, but they are not abnormal for the operation.

- (1) Slight flowing noise of refrigerant in the refrigerating cycle.
 - (2) Slight rubbing noise from the fan casing which is cooled and then gradually warmed as operation stops.
- The odor will possibly be emitted from the room air conditioner because the various odor, emitted by smoke, foodstuffs, cosmetics and so on, sticks to it. So the pre-filter and the evaporator regularly must be cleaned to reduce the odor.

Please contact your sales agent immediately if the air conditioner still fails to operate normally after the above inspections. Inform your agent of the model of your unit, production number, date of installation. Please also inform him regarding the fault.

Please note:

On switching on the equipment, particularly when the room light is dimmed, a slight brightness fluctuation may occur. This is of no consequence.

The conditions of the local Power Supply Companies are to be observed.

Please note:

On switching on the equipment, particularly when the room light is dimmed, a slight brightness fluctuation may occur. This is of no consequence.

The conditions of the local Power Supply Companies are to be observed.

Note

- Avoid using the room air conditioner for cooling operation when the outside temperature is below the minimum recommended temperature.

The recommended maximum and minimum operating temperatures of the hot and cold sides should be as below:

Single Split model connection (RAC-DJ** series)

		Cooling		Heating	
		Minimum	Maximum	Minimum	Maximum
Indoor	Dry bulb	70°F (21°C)	90°F (32°C)	68°F (20°C)	81°F (27°C)
	Wet bulb	59°F (15°C)	73°F (23°C)	–	–
Outdoor	Dry bulb	-0.4°F (-18°C)	114.8°F (46°C)	-5°F (-20.55°C)	75.2°F (24°C)
	Wet bulb	–	–	–	–